

PA-A2 Eyebolt Installation Instructions

Description

The contents of this eyebolt kit allow the rigging of various Mackie and EAW loudspeakers. Only use with loudspeakers specifically designed to use the PA-A2 kit.

PA-A2 Eyebolt Kit (Part No. 0028272) contents:

Part No.	Quantity	Description
0029818	4	Eyebolt, Forged shoulder, Black, M10 x 1.5 x 37 mm
0025068	4	Washer, Flat Black, M10
0032747	1	Instruction Sheet

Required Tools (not included):

6 mm Hex Driver

Safety First!

Before installing and using this product, please read these instructions carefully and keep them on hand for future reference. Additionally, refer to the loudspeaker product manual for detailed product-specific rigging information. Failure to follow the precautions in both documents may result in damage, injury, or even death.

! WARNING: This product has been designed for installation only by qualified personnel having the technical know-how and experience or specific instructions to ensure correct execution of all of the operations involved to prevent any risk to personal safety. It is strongly recommended that this product be installed only by professionals or specialized firms. When installing this product, always respect the safety standard. Do not install the product in any way that is not described in these instructions.

! WARNING: The eyebolt adapter kit has been tested to a Working Load Limit (WLL) of 545 kg / 1200 lb with a design factor of 5:1. The WLL derates to a 182 kg / 400 lb at a 45 degree pull. Do not use an eyebolt for an angled pull greater than 45 degrees. At least two eyebolts should be used in any PA-A2 install. Never apply a load that exceeds the Working Load Limit.

Before suspending the speaker, make all of the necessary calculations to ensure that all of the components are used within their nominal work load range. Remember that the weakest component determines the safety level of the entire installation.

Disclaimer:

LOUD Technologies Inc. continually engages in research related to product improvement. New material, production methods, and design refinements are introduced into existing products without notice as a routine expression of that philosophy. For this reason, any current LOUD Technologies Inc. product may differ in some respect from its published description, but will always equal or exceed the original design specifications unless otherwise stated.

Part No. SW0749 Rev B 05/09

© 2009 LOUD Technologies Inc. All Rights Reserved.

Eyebolt Installation

At least two eyebolts should be used in any installation utilizing the PA-A2 kit.

1. Using a 6 mm hex driver, remove the screws from the mounting points you wish to use.
2. Place the threaded part of the eyebolt through the washer.
3. Fully screw the eyebolt into the threaded insert of the speaker.

VERY IMPORTANT: Do not over-tighten the eyebolt, as this could damage the threaded insert of the speaker.

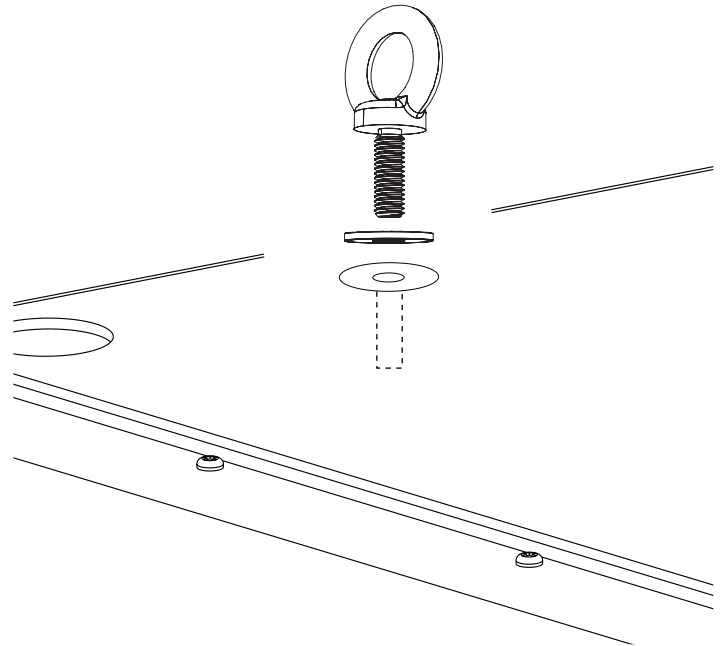

LOUD Technologies Inc. • 16220 Wood-Red Road NE
Woodinville • WA • 98072 • 800/258-6883
Outside the U.S. call 425/487-4333 • FAX 425/487-4337