

## SRT

### Professional Powered Loudspeaker Series

SRT™ Professional Powered Loudspeakers are designed for real-world working musicians, DJs, events, venues, and beyond.

The latest acoustic processing technology, powerful amplifiers, and the ultra-versatile SRT Mix Control™ means easy setup, incredible sound, and unbeatable reliability.

Built-Like-A-Tank™ construction features rugged molded cabinets and tough steel grilles that are built to last.

As the larger gigs come rolling in, your audience gets bigger, and your needs demand better sound and flexibility, SRT is YOUR Next Big Thing.

### APPLICATIONS:

Singer-songwriters, announcement PA, karaoke, clubs / cafés, houses of worship, schools, small restaurants, outdoor events / barbecues, banquet halls, conference rooms, boardrooms, and many, many more.

### FEATURES:

#### ■ A True Workhorse for Gigging Professionals

- Powerful 1600W Class-D amplifiers designed for ultra-reliable, consistent performance
- Custom high-efficiency transducers ensure maximum clarity and accuracy
- Built-Like-A-Tank™ to conquer every gig while lightweight for easy loading
- Universal Power Supply (100-240VAC) with Power Factor Correction for stable operation even with unstable AC power

#### ■ Advanced Impulse™ DSP – Proprietary Acoustic Tuning

- Crystal clear sound across the entire dispersion zone means the whole room is the sweet spot
- Precision crossover and transducer time-alignment ensures balanced and accurate sound

#### ■ Custom Sym-X™ Horn

- Allows for total efficiency from the HF transducer minimizing distortion and increasing output
- Creates a perfectly symmetrical, flat response at the crossover point for exceptionally smooth midrange
- The horn-loading frequency is set below the drivers' LF capability allowing for maximum efficiency and optimal performance at the crossover point
- Coverage: 90° horizontal x 60° vertical

#### ■ Transparent System Limiting and Protection

- Dedicated processing module monitors and protects the amplifier in real time
- Sound quality and tonal balance is maintained even under heavy limiting
- Utilizing powerful multi-band compression, the amplifier can target specific frequency ranges to prevent the system from being overloaded rather than turn everything down at the expense of overall output
- Input limiting keeps your source signal in check so if you're sending audio that's a bit too hot, the speaker will cool it down

#### ■ SRT Mix Control™ Built-in 4-Channel Digital Mixer with Bluetooth®

- Dual independent channels that support mic, line, and instrument signals
- Dedicated 1/8" stereo aux channel
- Stream music from any Bluetooth® enabled device
- High-contrast full color display for easy single-knob access to mixer and processing
- Adjust channel levels and EQ
- Application and venue specific voicing modes
- Alignment delay – up to 100 feet
- Save and recall up to 10 user preset
- Screensaver plus dimmer and contrast control
- System lock with 4-digit passcode
- Front LED on, off and signal present modes

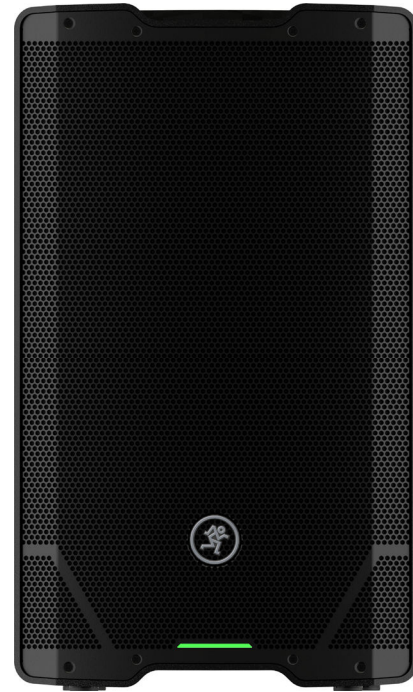

## SRT FEATURES CONTINUED...

- **Complete Wireless Control via the SRT Connect™ App**
  - The SRT Connect™ app gives you access to all adjustments and settings including EQ, levels, and presets
  
- **Wirelessly link SRT speakers together for music streaming applications plus complete control over both speakers**
  - The latest Bluetooth technology allows up to 100 meters of range between linked speakers
  - Stereo or dual zone linking modes allows discrete control over the inputs and outputs of the entire system across two rooms or zones
  - Creates an incredibly clean setup in minutes
  
- **Versatile configuration options**
  - Dual-angled cabinet design allows for use as a high-performance floor monitor
  - Dual angle pole-mount provides optimal coverage and minimal reflections in most venues; 7-degree downward tilt is perfect for when the speakers are on elevated stages
  - M10 flypoints for professional installation
  
- **Step up your low-end with the SR18S Powered Subwoofer**
  - High efficiency 1600W amplifier
  - Heavy-duty custom 18" woofer
  - Versatile I/O
  - Fully adjustable crossover frequency
  - Custom voicing modes
  - Polarity invert switch
  - Integrated pole cup

## SRT SPECIFICATIONS

### Acoustic Performance

Frequency Response (-10 dB)	47 Hz - 20 kHz [SRT210] 44 Hz - 20 kHz [SRT212] 42 Hz - 20 kHz [SRT215]
Frequency Response (-3 dB)	57 Hz - 20 kHz [SRT210] 52 Hz - 20 kHz [SRT212] 46 Hz - 20 kHz [SRT215]
Horizontal Coverage	90°
Vertical Coverage	60°
Maximum SPL Peak	128 dB [SRT210] 132 dB [SRT212] 133 dB [SRT215]
Monitor Angle	45°

### Transducers

Low Frequency	10 in / 254 mm [SRT210] 12 in / 305 mm [SRT212] 15 in / 381 mm [SRT215] with ferrite
High Frequency	1.4 in / 36 mm polymer compression driver

### Power Amplifiers

System Power Amplification	1600 watts peak
Rated Power	
Low Frequency Power Amplifier	1400 watts peak
Rated Power	
Rated THD	<1%
Cooling Design	Convection Class D
High Frequency Power Amplifier	200 watts peak
Rated Power	
Rated THD	<1%
Cooling Design	Convection Class D

### System Processing

Voicing	5 speaker modes
Subwoofer HPF	Off, SR18S, DRM18S, Var
Input EQ	3-band
Delay	0 - 100 ms

### Equalization

Low	±12 dB @ 80 Hz
Mid	±12 dB @ 2.5 kHz
High	±12 dB @ 5 kHz
HPF	80 Hz - 150 Hz (Var)

**Like us**

**Follow us**

**Watch our dang videos**

## SRT SPECIFICATIONS CONTINUED...

### Input / Output

Input Type	2x Female XLR Balanced 1/4" Balanced 1/8" Stereo
Mic-Line Impedance	20 kΩ balanced
1/4" TS, Wide-Z™ Impedance	100 kΩ balanced
Direct Out and Mix Out	Male XLR Balanced
Mix Out Impedance	300 Ω balanced
Main Control	Rotating Knob

### Bluetooth Information

Bluetooth Protocol	4.2
Bluetooth Function	Audio Streaming and User Interface Control
Bluetooth Class	Class 1

### Electronic Crossover

Crossover Type	24 dB / octave
Crossover Frequency	2.0 kHz

### Line Input Power

Detachable line cord	~100 – 240 VAC, 50 – 60 Hz, 110W ~220 – 240 VAC, 50 – 60 Hz, 110W
AC Connector	3-Pin IEC 250 VAC, 10 A male
Power Supply Type	Switchmode

### Safety Features

Input Protection	Peak and RMS limiting, power supply and amplifier thermal protection
Display LEDs	Defeatable front power, speaker control
Status Info	Input and output levels, voicing mode, sub HPF, EQ and delay settings

### Construction Features

Basic Design	Asymmetrical
Enclosure Material	Black Polypropylene
Enclosure Finish	Light Black Texture
Grille Material	16-18 gauge perforated steel w/nylon net backing
Grille Finish	Powder-coated black
Handles	One [SRT210], two on each side and one partial on top [SRT212 and SRT215]
Display LEDs	
Front	Power / Signal
Rear	Speaker Control
Operating Temperature	0 – 40 °C 32 – 104 °F

### Physical Properties (product)

#### SRT210:

Height:	23.0 in / 584 mm
Width:	15.1 in / 384 mm
Depth:	12.9 in / 328 mm
Weight:	28.2 lb / 12.8 kg

#### SRT212:

Height:	25.9 in / 658 mm
Width:	15.2 in / 386 mm
Depth:	14.2 in / 361 mm
Weight:	32.5 lb / 14.7 kg

#### SRT215:

Height:	28.8 in / 732 mm
Width:	17.6 in / 447 mm
Depth:	15.4 in / 391 mm
Weight:	37.1 lb / 16.8 kg

## SRT SPECIFICATIONS CONTINUED...

### Physical Properties (packaged product)

<b>SRT210:</b>	
Height:	27.2 in / 691 mm
Width:	17.7 in / 450 mm
Depth:	16.5 in / 419 mm
Weight:	33.7 lb / 15.3 kg
<b>SRT212:</b>	
Height:	29.9 in / 759 mm
Width:	18.1 in / 460 mm
Depth:	17.7 in / 450 mm
Weight:	38.4 lb / 17.4 kg
<b>SRT215:</b>	
Height:	32.3 in / 820 mm
Width:	20.5 in / 521 mm
Depth:	18.9 in / 480 mm
Weight:	43.7 lb / 19.8 kg

### Options

SRT210 Cover	P/N 2036809-54
SRT212 Cover	P/N 2036809-55
SRT215 Cover	P/N 2036809-56
SRT210 Rolling Bag	P/N 2036809-57
SRT212 Rolling Bag	P/N 2036809-58
SRT215 Rolling Bag	P/N 2036809-59
T100 Loudspeaker Tripod Stand	P/N 2052464
SPM400 Loudspeaker Pole Mount	P/N 2051055
PA-A2 Eyebolt Kit	P/N 2051054

### Ordering Information

<b>SRT210 – 10" 1600W Professional Powered Loudspeaker</b>	
	P/N 2051849-00 (US)
	P/N 2051849-01 (EU)
	P/N 2051849-03 (UK)
	P/N 2051849-04 (AU)
	P/N 2051849-05 (CN)
	P/N 2051849-06 (BZ -120V)
	P/N 2051849-07 (AR)
	P/N 2051849-08 (KR)

<b>SRT212 – 12" 1600W Professional Powered Loudspeaker</b>	
	P/N 2051848-00 (US)
	P/N 2051848-01 (EU)
	P/N 2051848-03 (UK)
	P/N 2051848-04 (AU)
	P/N 2051848-05 (CN)
	P/N 2051848-06 (BZ -120V)
	P/N 2051848-07 (AR)
	P/N 2051848-08 (KR)

<b>SRT215 – 15" 1600W Professional Powered Loudspeaker</b>	
	P/N 2051847-00 (US)
	P/N 2051847-01 (EU)
	P/N 2051847-03 (UK)
	P/N 2051847-04 (AU)
	P/N 2051847-05 (CN)
	P/N 2051847-06 (BZ -120V)
	P/N 2051847-07 (AR)
	P/N 2051847-08 (KR)

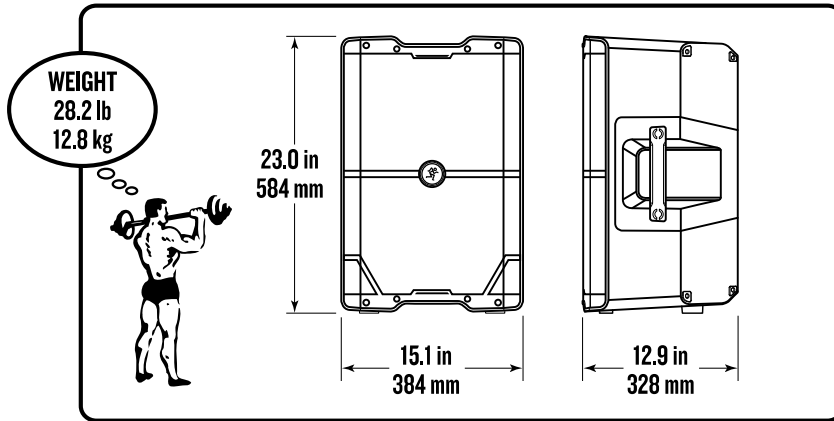
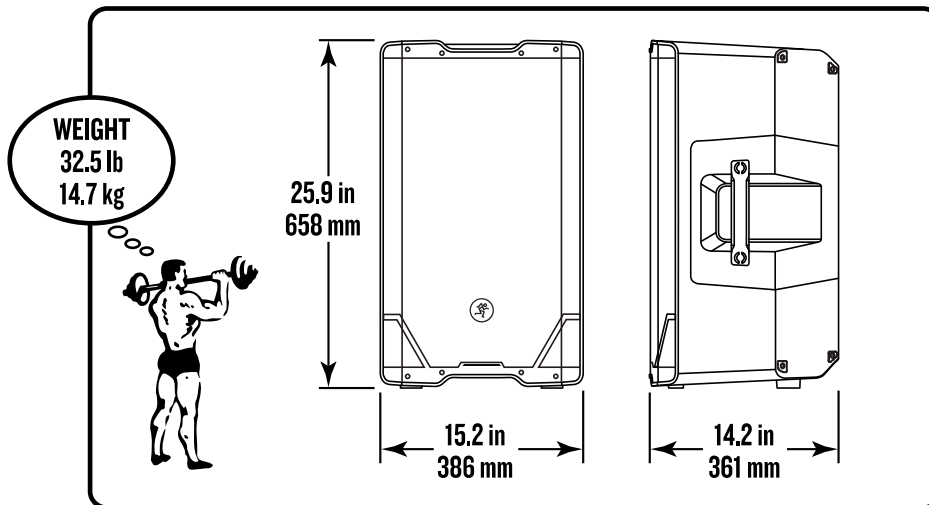
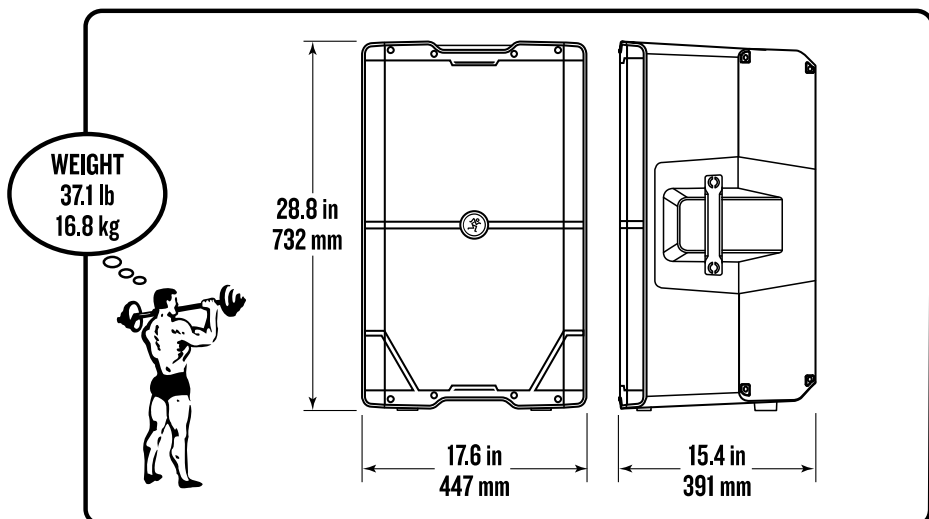
**SRT DIMENSIONS****SRT210****SRT212****SRT215**

**SRT BLOCK DIAGRAM – SRT MIX CONTROL™**

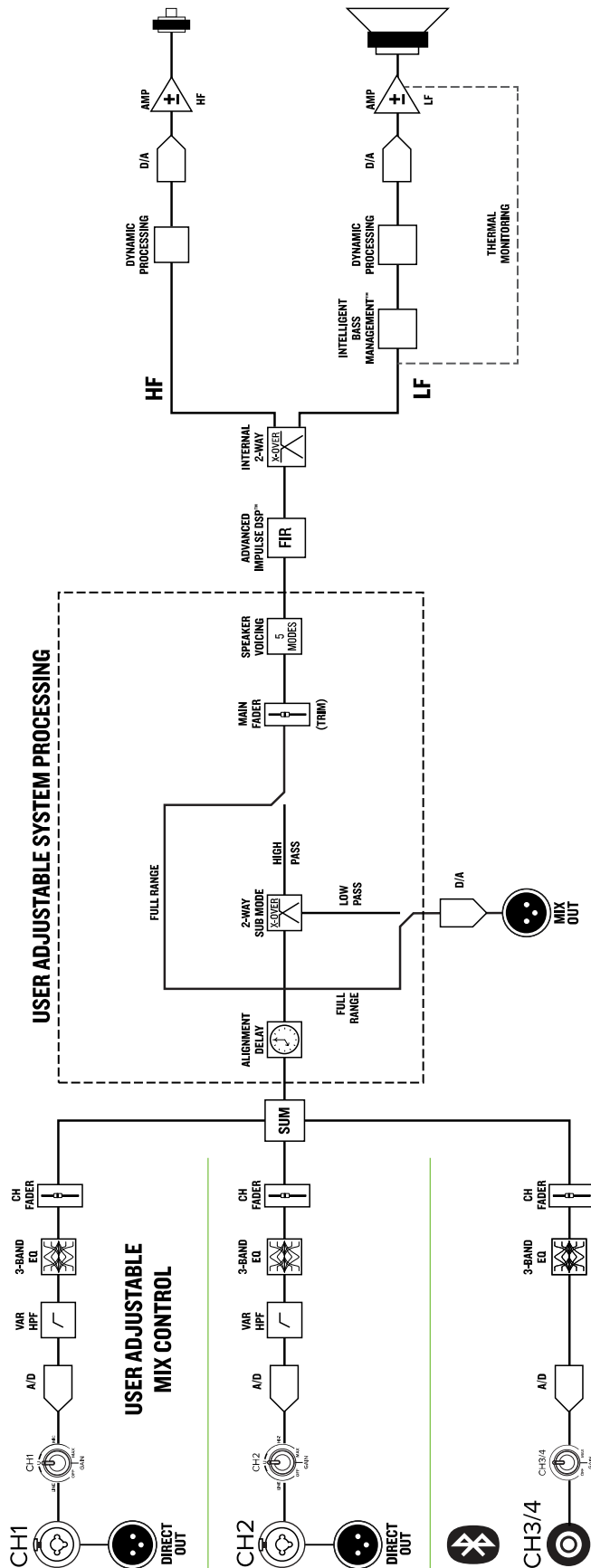

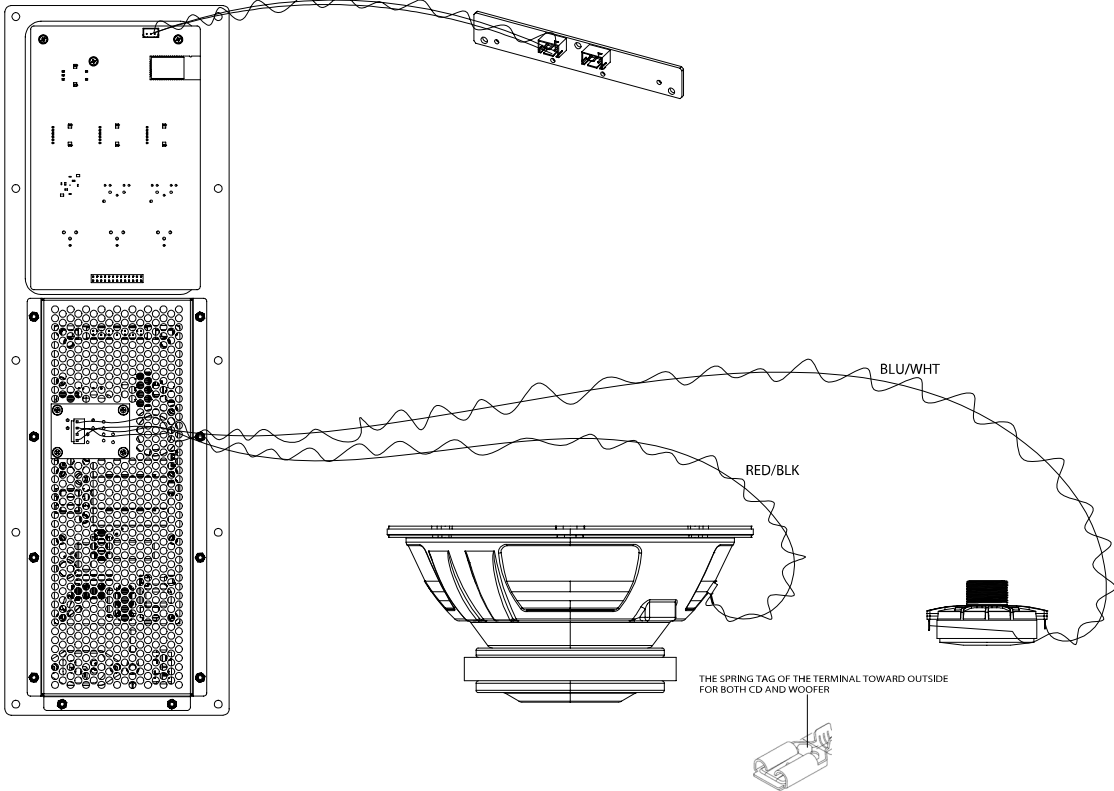
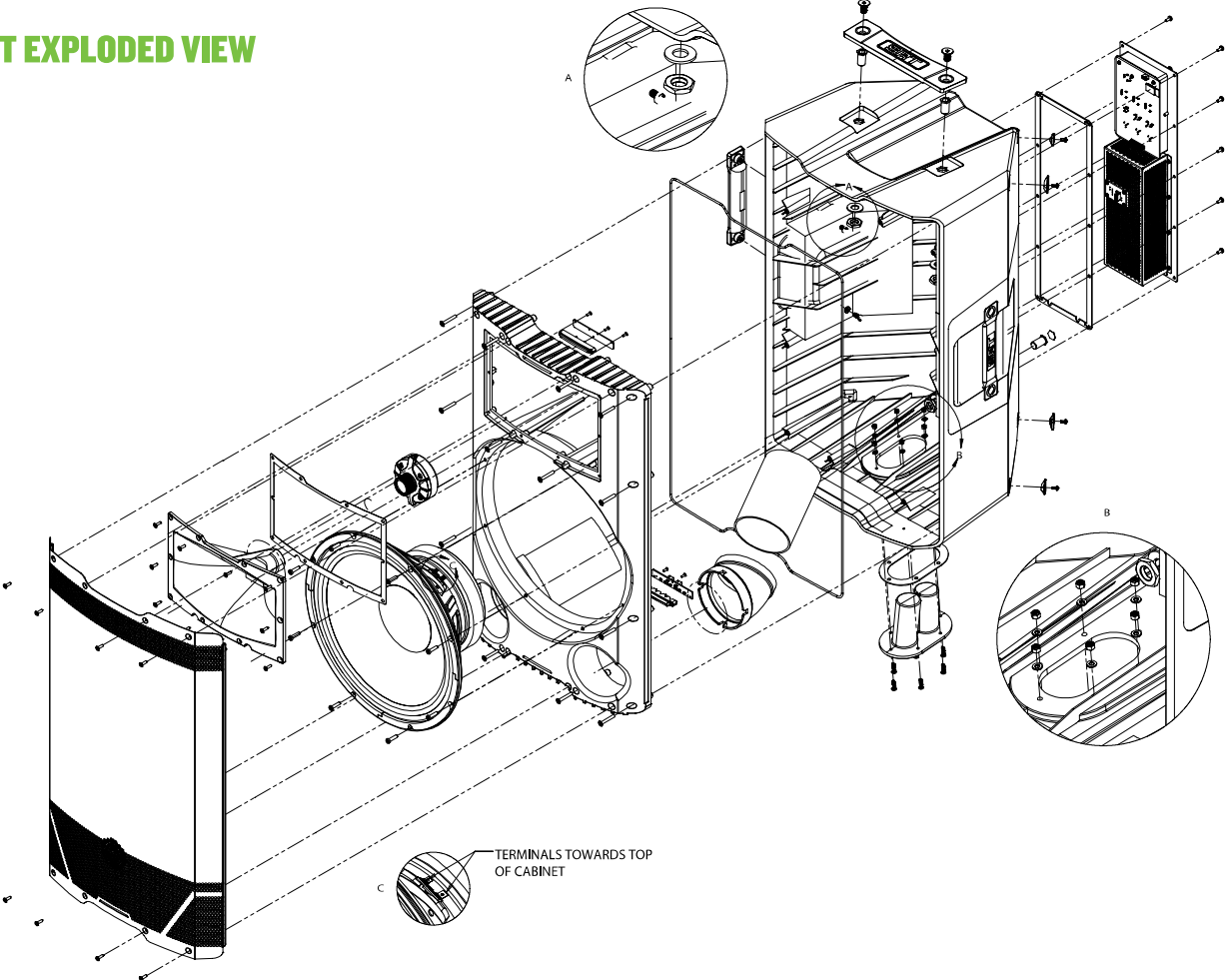
**SRT EXPLODED VIEW**

## SRT MAGNITUDE RESPONSE LEGEND & GRAPHS

**FLAT Voicing Mode** – No question about this speaker mode; it’s flat! This plug-and-play mode is perfect for singer-songwriters and listening to mastered music and is optimized to maintain tonal balance at peak output volume.

**LIVE Voicing Mode** – This mode features an upper bass parametric scoop to reduce unwanted low frequency color and adds boost to upper mid-range and high frequencies.

**SPEECH Voicing Mode** – This mode features a significant low frequency roll-off to attenuate low-end vocal boom. It also adds boost to high frequencies – critical for speech intelligibility – and notches part of the spectrum where feedback squeal commonly lives. Additionally, a dedicated compressor engages in this mode to help control the aggressive dynamics generated by speech. This process chain is perfect for applications where highly amplified, intelligible speech is the desired output.

**CLUB Voicing Mode** – This mode is full range, but focuses on increased bass and brilliant high frequencies. This is the place to start for most DJ / music playback applications.

**MONITOR Voicing Mode** – Monitor mode was tailored to reduce excess low frequency output when coupled with the ground, while also reducing mid-range bite for the artist(s). This mode should only be engaged when the speaker is in its monitor orientation on a stage or floor... if not, the low-end will sound very lean.



All Magnitude Response graphs were generated using a Klippel NFS.

## SRT210 MAGNITUDE RESPONSE

█ FLAT   
 █ LIVE   
 █ SPEECH   
 █ CLUB   
 █ MONITOR

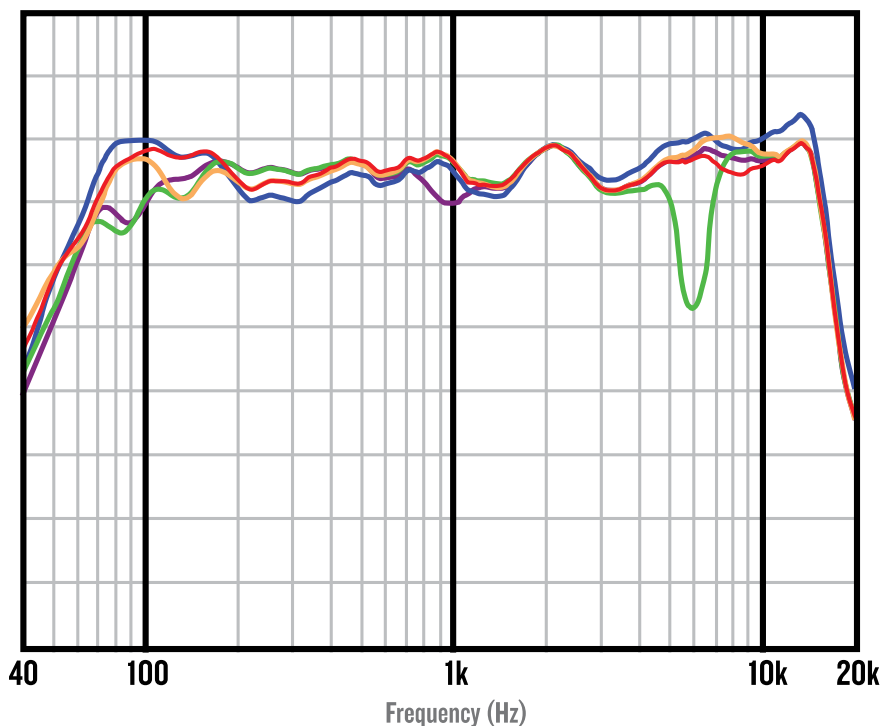



### SRT212 MAGNITUDE RESPONSE

— FLAT   
 — LIVE   
 — SPEECH   
 — CLUB   
 — MONITOR

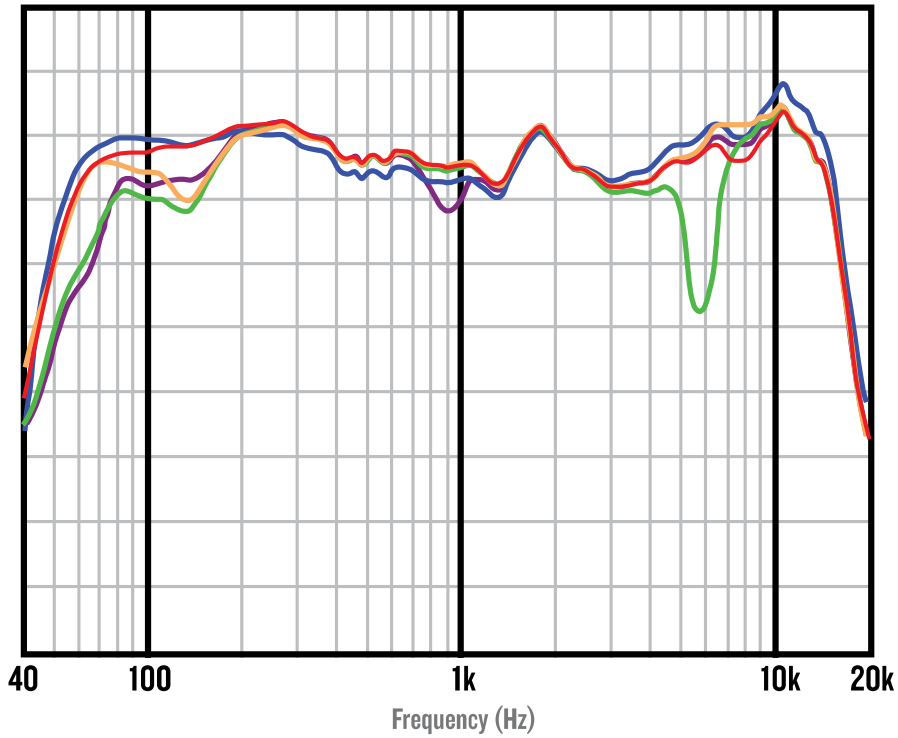

### SRT215 MAGNITUDE RESPONSE

— FLAT   
 — LIVE   
 — SPEECH   
 — CLUB   
 — MONITOR

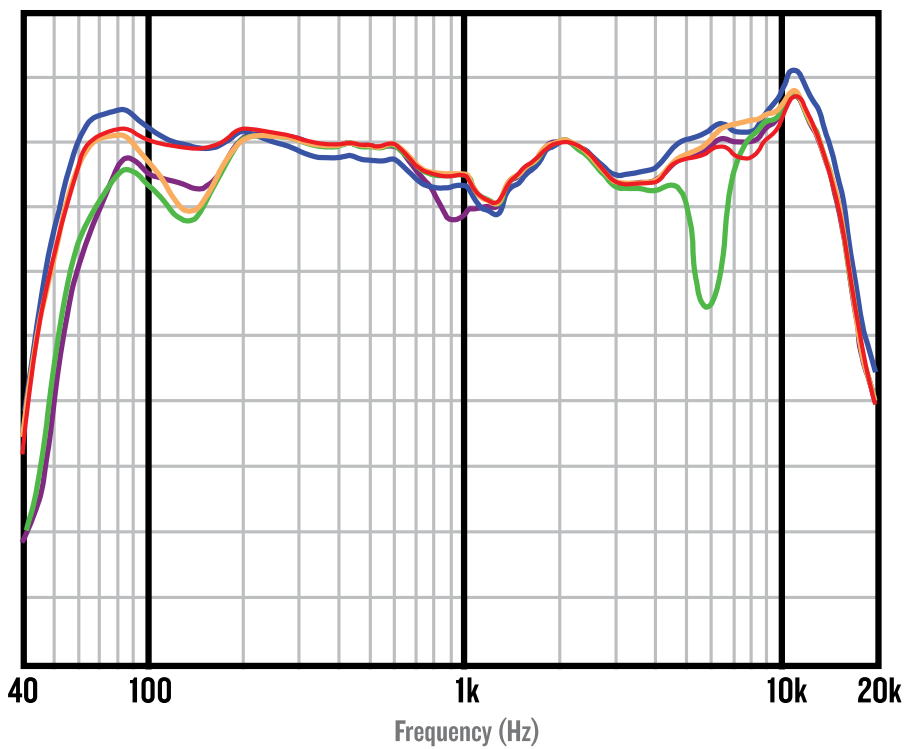

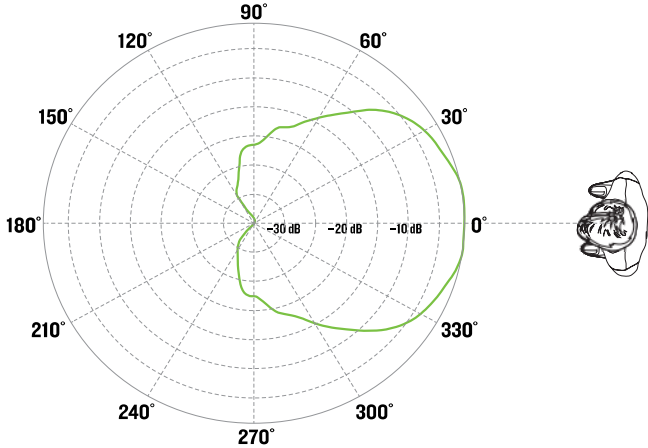
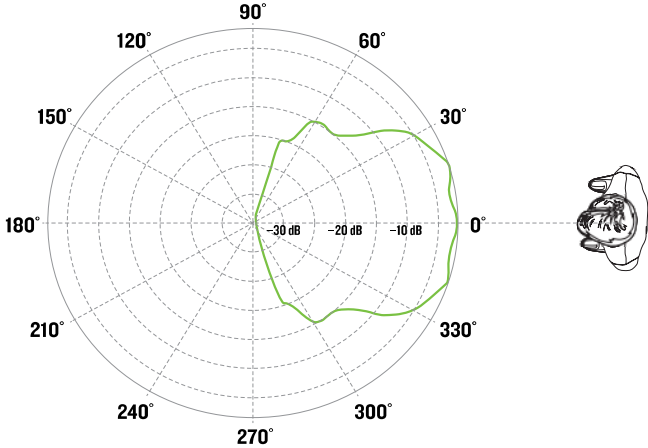
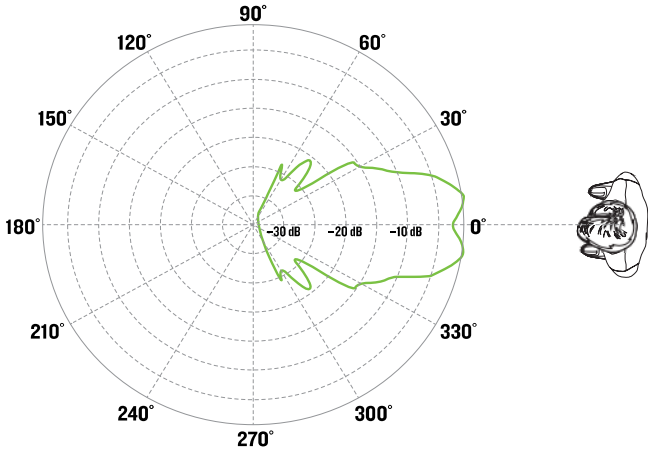
**SRT POLAR MEASUREMENTS OF HORIZONTAL DISPERSION (MF + HF)**
**5 kHz**

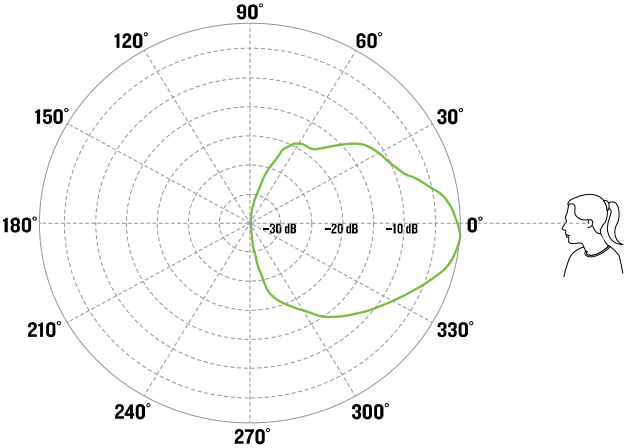
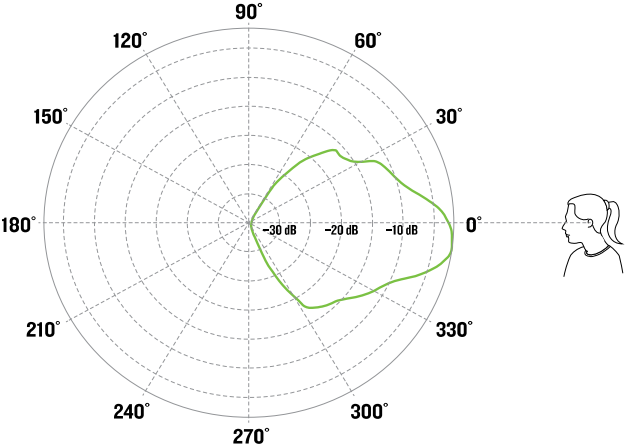
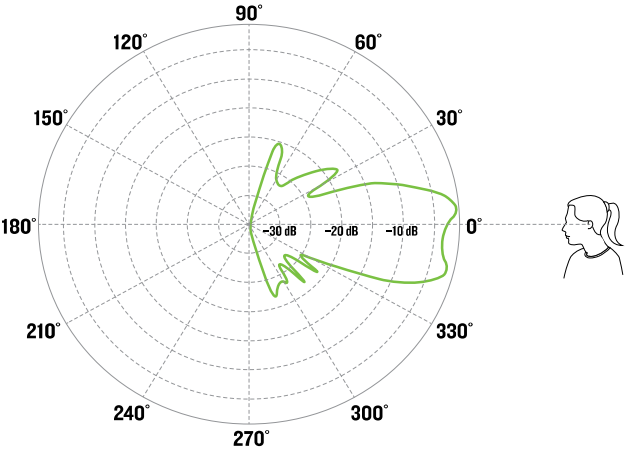
**10 kHz**

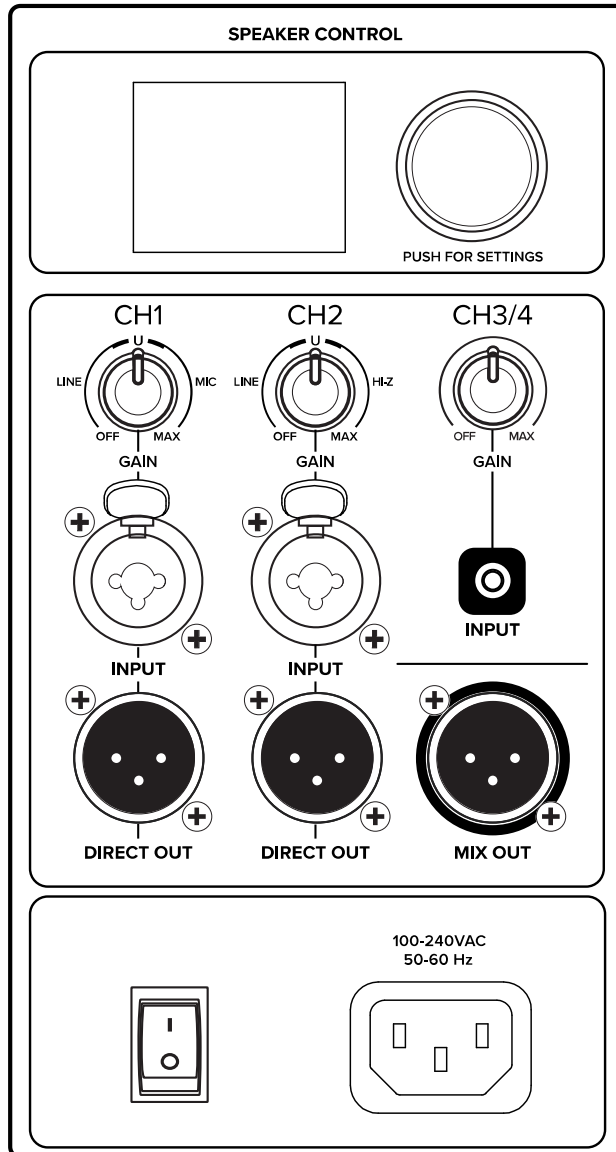
**15 kHz**

**SRT POLAR MEASUREMENTS OF VERTICAL DISPERSION (MF + HF)**
**5 kHz**

**10 kHz**

**15 kHz**

**SRT LOUDSPEAKER REAR PANEL**

Electronic files for this product are available at:  
[www.mackie.com](http://www.mackie.com)

Specification Sheet	SRT_SS.PDF
Owner's Manual	SRT_OM.PDF

LOUD Audio, LLC. is always striving to improve our products by incorporating new and improved materials, components, and manufacturing methods. Therefore, we reserve the right to change these specifications at any time without notice.

"Mackie" and the "Running Man" figure are registered trademarks of LOUD Audio, LLC. All other brands mentioned are trademarks or registered trademarks of their respective holders, and are hereby acknowledged.